



PISTON PUMPS

TECHNICAL CATALOGUE - REV. 00/2017

Capitanio Airpumps s.r.l. – Via Brigata Mazzini 35/A 36016 – Thiene (VI)
Tel. +39 0445 185.65.65 – Fax. +39 0445 185.65.00
www.airpumps.it capitanio@airpumps.it

INDEX

Capitano Airpumps	4
Glue.....	5
Alko N.....	6
Alko AP.....	7
Alko SDE.....	8
Alko SSDE.....	9
Alko200 - R1.....	10
Fox Colla.....	12
200 liter Barrel Pumps	13
PF 643580	14
PF 803580	15
PF 12580	16
Fox Fusto	17
1000 liter Tank Pumps	18
PF 643580 - Cisterna.....	19
Fox Cisterna.....	20
Oils and Lubricants	21
Oil 287	22
Fox Oil.....	23
General Application Pumps	24
Fox Muro	25
Accessories	26
Customization and other accessories.....	28
Barrel Covers.....	29
Tanks & Barrels.....	30
Complete Sets.....	31
Inline Filter.....	32
Heating Bands 30L	33
Heating Bands 200L	34
External Heater	35
Lifters.....	36

CAPITANIO AIRPUMPS



WHO WE ARE

Since 1979 Capitano Airpumps designs and produces **double diaphragm** and **piston** air operated pumps, **valves** and **pulsation dampeners**. Suitable for every kind of fluid, adjustable flow and pressure, reversible. Every product is very High Quality and **MADE IN ITALY**.

REAL ADDED VALUE

Capitano Airpumps is a dynamic company, fast and punctual in both administration and production. Thanks to this philosophy the company is able to work on **customized projects and products**, offer **prompt technical assistance** and have **spare parts** always ready to be shipped **in stock**.

PATENTS

Capitano Airpumps owns a few patented products, like the innovative **Reverse system**, the **double diaphragm process Valve** and the active **double diaphragm Pulsation Dampener**. Other products are patent pending.



GLUE



ALKO N

STANDARD APPLICATION

Glue

FEATURES

Stainless Steel frame, NO gaskets sealing, Low-Cost, Easily cleanable



TECHNICAL DATA

Type	Single Effect
Adjustable Flow Rate	4,8 l/min
Pressure Ratio	2,5:1
Outlet Port	3/8" Gas Thread (Hose nozzle Ø17 mm)
Maximum cycles per minute	140
Air consumption per cycle	0,28 dm ³
Air consumption at 55 cpm	39 NI/min
Air Inlet	1/4" Gas
Air Supply Pressure (Min / Max)	1 / 6.8 bar
Weight	6 Kg
Noise Level	<78 dB [A]

DIMENSIONS

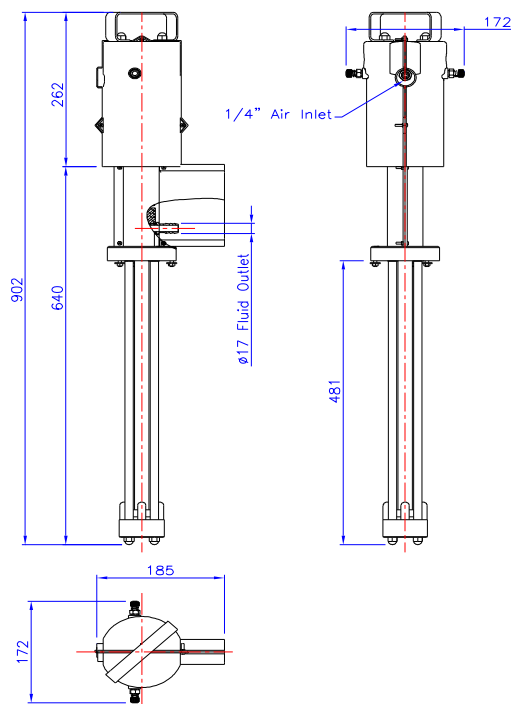

ALKO AP

STANDARD APPLICATION

Glue

FEATURES

Stainless Steel frame, Brass inlet valve, Low-Cost, Easily cleanable



TECHNICAL DATA

Type	Single Effect
Adjustable Flow Rate	5,6 l/min
Pressure Ratio	2,5:1
Outlet Port	3/8" Gas Thread (Hose nozzle Ø17 mm)
Maximum cycles per minute	140
Air consumption per cycle	0,28 dm ³
Air consumption at 55 cpm	39 NI/min
Air Inlet	1/4" Gas
Air Supply Pressure (Min / Max)	1 / 6.8 bar
Weight	6 Kg
Noise Level	<78 dB [A]

DIMENSIONS

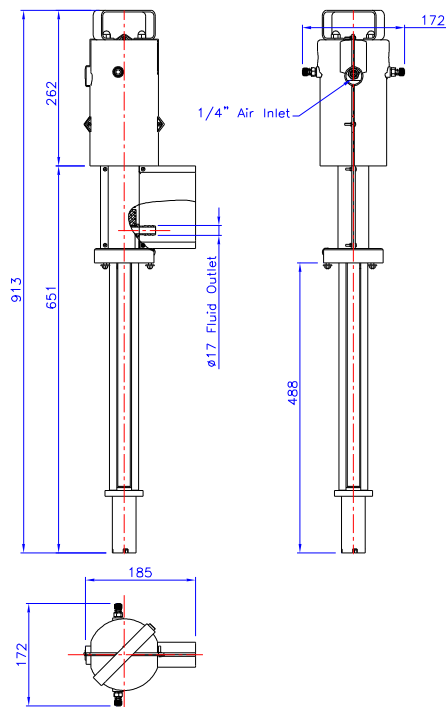

ALKO SDE

STANDARD APPLICATION

Glue

FEATURES

Stainless Steel frame, Brass inlet valve



TECHNICAL DATA

Type	Double Effect
Adjustable Flow Rate	7,1 l/min
Pressure Ratio	2,5:1
Outlet Port	3/8" Gas Thread (Hose nozzle Ø17 mm)
Maximum cycles per minute	140
Air consumption per cycle	0,28 dm ³
Air consumption at 55 cpm	39 NI/min
Air Inlet	1/4" Gas
Air Supply Pressure (Min / Max)	1 / 6.8 bar
Weight	8 Kg
Noise Level	<78 dB [A]

DIMENSIONS

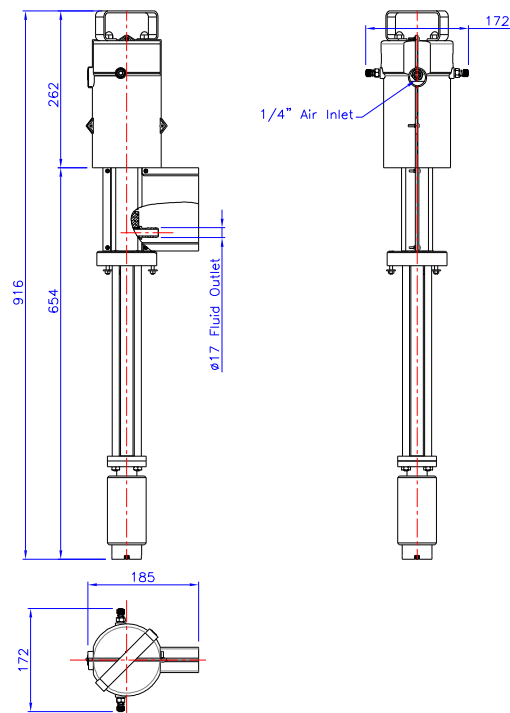

ALKO SSDE

STANDARD APPLICATION

Glue

FEATURES

Stainless Steel frame, Brass inlet valve



TECHINCAL DATA

Type	Double Effect
Adjsutable Flow Rate	7,7 l/min
Pressure Ratio	5:1
Outlet Port	3/8" Gas Thread (Hose nozzle Ø17 mm)
Maximum cycles per minute	53
Air consumption per cylce	0,8 dm ³
Air consumption at 55 cpm	42 Nl/min
Air Inlet	1/4" Gas
Air Supply Pressure (Min / Max)	1 / 6.8 bar
Weight	10 Kg
Noise Level	<78 dB [A]

DIMENSIONS

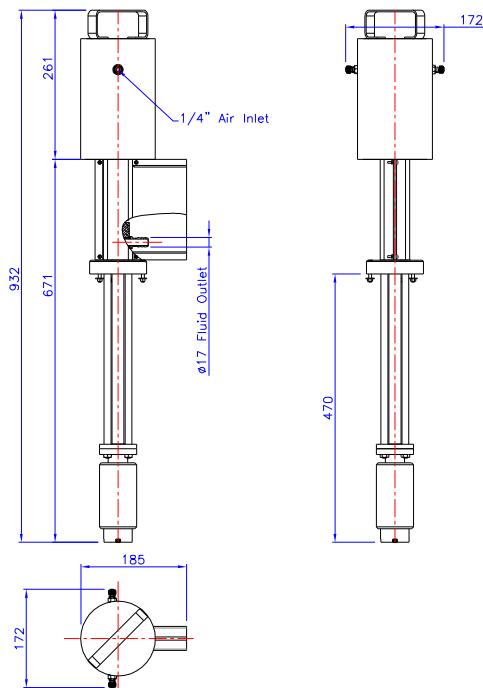

ALKO200 - R1

STANDARD APPLICATION

Heated Glue

FEATURES

Stainless Steel frame, Brass inlet and outlet bodies, Fixed outlet, Stainless Steel barrel cover
heating resistance regulated by a digital thermo-controller (included), resistance kit easy to assemble and disassemble

thermo-controller can be either separated or incorporated on the pump



TECHNICAL DATA

Type	Double Effect
Adjustable Flow Rate	6,9 l/min
Pressure Ratio	2,5:1
Outlet Port	3/8" Gas Thread (Hose nozzle Ø19 mm)
Maximum cycles per minute	140
Air consumption per cycle	0,28 dm ³
Air consumption at 55 cpm	39 NI/min
Air Inlet	1/4" Gas
Air Supply Pressure (Min / Max)	1 / 6.8 bar
Weight	10 Kg
Noise Level	<78 dB [A]
Voltage and Frequency	220V 50Hz

DIMENSIONS

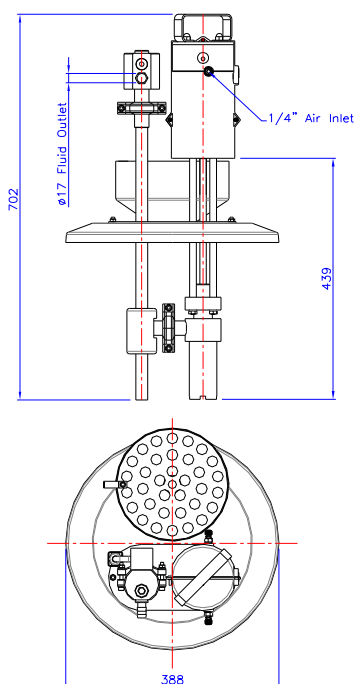

CONFIGURATIONS

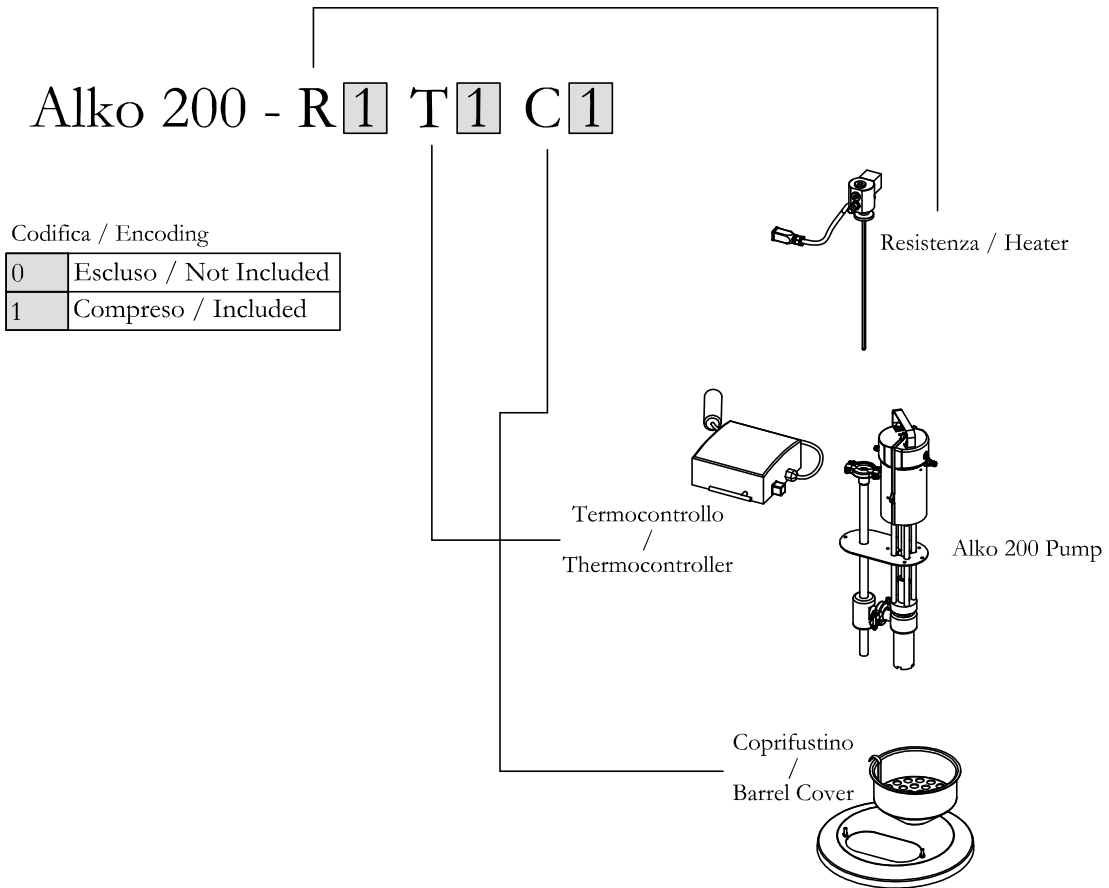

FOX COLLA

STANDARD APPLICATION

Glue, multiple distribution centralized systems

FEATURES

Stainless Steel frame, PTFE Gaskets, High performances



TECHNICAL DATA

Type	Double Effect
Adjustable Flow Rate	30 l/min
Pressure Ratio	5:1
Outlet Port	3/4" Gas Thread
Inlet Port	1" 1/4" Gas Thread
Maximum cycles per minute	165
Air consumption per cycle	1,19 dm ³
Air consumption at 55 cpm	196 NI/min
Air Inlet	1/4" Gas
Air Supply Pressure (Min / Max)	1 / 6.8 bar
Weight	16 Kg
Noise Level	<78 dB [A]

DIMENSIONS

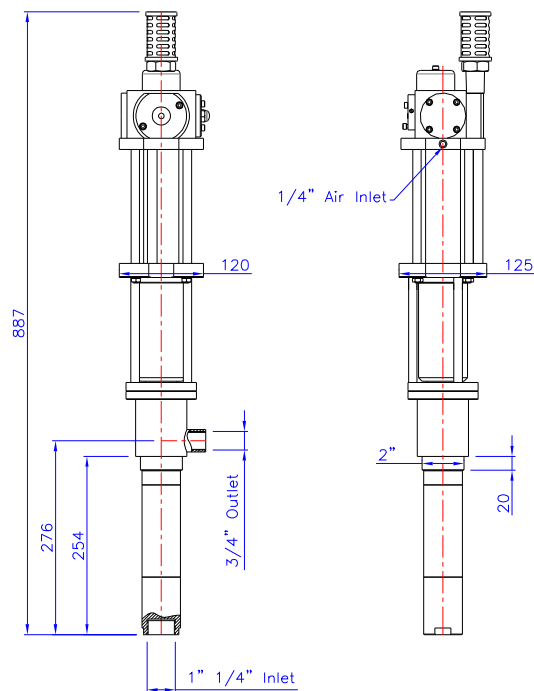

200 LITER BARREL PUMPS



PF 643580

STANDARD APPLICATION

Viscous fluids in 200 liter barrels

FEATURES

Stainless Steel frame, PTFE Gaskets, divorced pump with gasket kit immersed in the fluid



TECHINCAL DATA

Type	Double Effect
Adjsutable Flow Rate	12 l/min
Pressure Ratio	2,4:1
Outlet Port	1/2" Gas (Hose nozzle Ø19 mm)
Maximum cycles per minute	106
Air consumption per cylice	0,62 dm ³
Air consumption at 55 cpm	66 Nl/min
Air Inlet	1/4" Gas
Air Supply Pressure (Min / Max)	1 / 6.8 bar
Weight	10 Kg
Noise Level	<78 dB [A]

DIMENSIONS

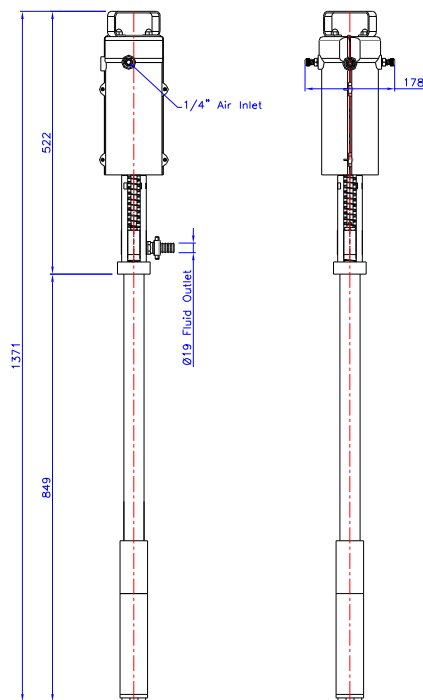

PF 803580

STANDARD APPLICATION

Viscous fluids in 200 liter barrels

FEATURES

Stainless Steel frame, PTFE Gaskets, divorced pump with gasket kit immersed in the fluid



TECHNICAL DATA

Type	Double Effect
Adjustable Flow Rate	7,7 l/min
Pressure Ratio	5:1
Outlet Port	1/2" Gas (Hose nozzle Ø19 mm)
Maximum cycles per minute	53
Air consumption per cycle	0,95 dm ³
Air consumption at 55 cpm	50 NI/min
Air Inlet	1/4" Gas
Air Supply Pressure (Min / Max)	1 / 6.8 bar
Weight	12 Kg
Noise Level	<78 dB [A]

DIMENSIONS

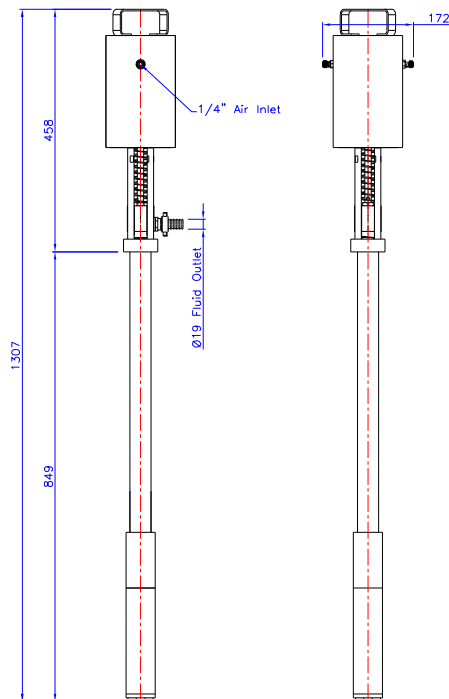

PF 12580

STANDARD APPLICATION

Viscous fluids in 200 liter barrels

FEATURES

Stainless Steel frame, PTFE Gaskets, divorced pump with gasket kit immersed in the fluid



TECHNICAL DATA

Type	Double Effect
Adjustable Flow Rate	11 l/min
Pressure Ratio	12:1
Outlet Port	1/2" Gas (Hose nozzle Ø19 mm)
Maximum cycles per minute	55
Air consumption per cycle	2 dm ³
Air consumption at 55 cpm	110 Nl/min
Air Inlet	1/4" Gas
Air Supply Pressure (Min / Max)	1 / 6.8 bar
Weight	17 Kg
Noise Level	<78 dB [A]

DIMENSIONS

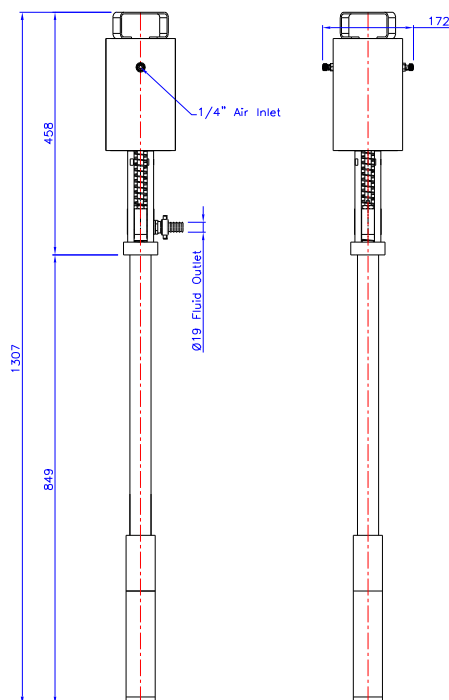

FOX FUSTO

STANDARD APPLICATION

Viscous fluids in 200 liter barrels

FEATURES

Stainless Steel frame, PTFE Gaskets, High performances



TECHNICAL DATA

Type	Double Effect
Adjustable Flow Rate	30 l/min
Pressure Ratio	5:1
Outlet Port	3/4" Gas Thread
Maximum cycles per minute	165
Air consumption per cycle	1,19 dm ³
Air consumption at 55 cpm	196 NI/min
Air Inlet	1/4" Gas
Air Supply Pressure (Min / Max)	1 / 6.8 bar
Weight	16 Kg
Noise Level	<78 dB [A]

DIMENSIONS

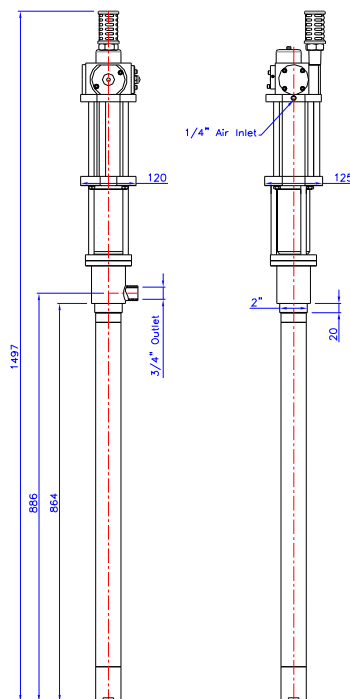

1000 LITER TANK PUMPS



PF 643580 - CISTERNA

STANDARD APPLICATION

Viscous fluids in 1000 liter tanks

FEATURES

Stainless Steel frame, PTFE Gaskets, divorced pump with gasket kit immersed in the fluid



TECHNICAL DATA

Type	Double Effect
Adjustable Flow Rate	12 l/min
Pressure Ratio	2,4:1
Outlet Port	1/2" Gas (Hose nozzle Ø19 mm)
Maximum cycles per minute	106
Air consumption per cycle	0,62 dm ³
Air consumption at 55 cpm	66 Nl/min
Air Inlet	1/4" Gas
Air Supply Pressure (Min / Max)	1 / 6.8 bar
Weight	10 Kg
Noise Level	<78 dB [A]

DIMENSIONS

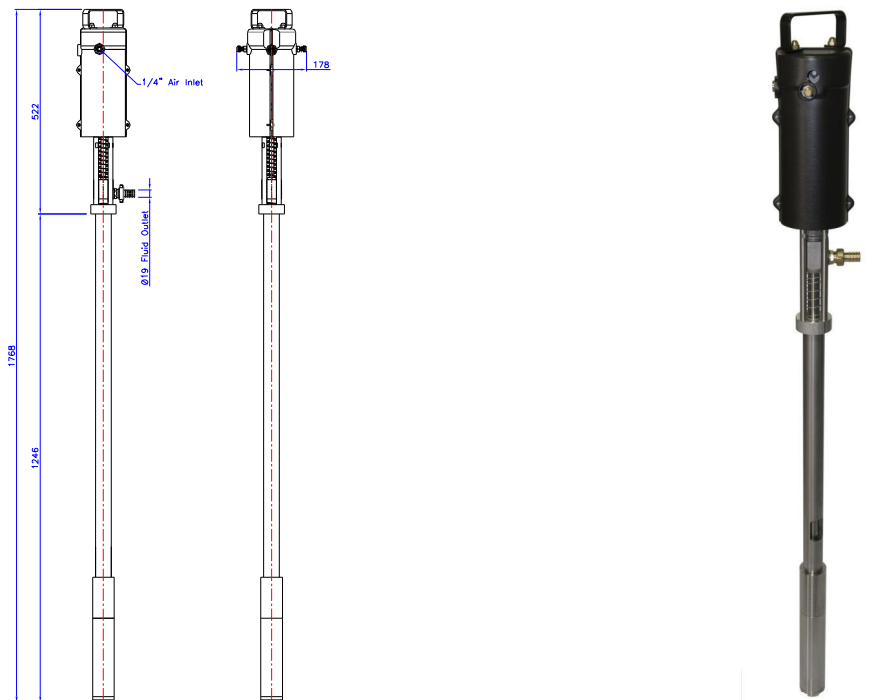

FOX CISTERNA

STANDARD APPLICATION

Viscous fluids in 1000 liter tanks

FEATURES

Stainless Steel frame, PTFE Gaskets, High performances



TECHNICAL DATA

Type	Double Effect
Adjustable Flow Rate	30 l/min
Pressure Ratio	5:1
Outlet Port	3/4" Gas Thread
Maximum cycles per minute	165
Air consumption per cycle	1,19 dm ³
Air consumption at 55 cpm	196 NI/min
Air Inlet	1/4" Gas
Air Supply Pressure (Min / Max)	1 / 6.8 bar
Weight	16 Kg
Noise Level	<78 dB [A]

DIMENSIONS

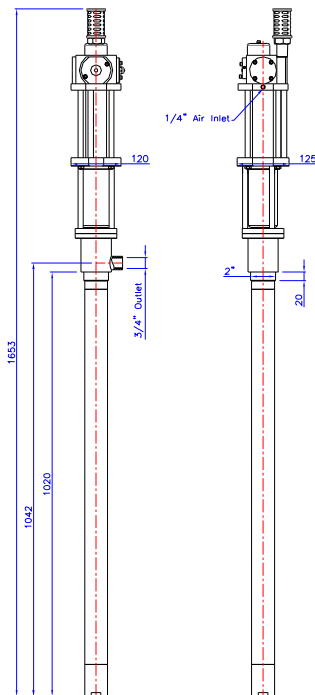

OILS AND LUBRICANTS



OIL 287

STANDARD APPLICATION

Oils, lubricants, multiple distribution centralized systems

FEATURES

High Performances, extremely reliable



TECHNICAL DATA

Type	Double Effect
Adjustable Flow Rate	9 l/min
Pressure Ratio	7:1
Outlet Port	3/4" Gas Thread
Maximum cycles per minute	88
Air consumption per cycle	0,8 dm ³
Air consumption at 55 cpm	70 NI/min
Air Inlet	1/4" Gas
Air Supply Pressure (Min / Max)	1 / 6.8 bar
Weight	7 Kg
Noise Level	<78 dB [A]

DIMENSIONS

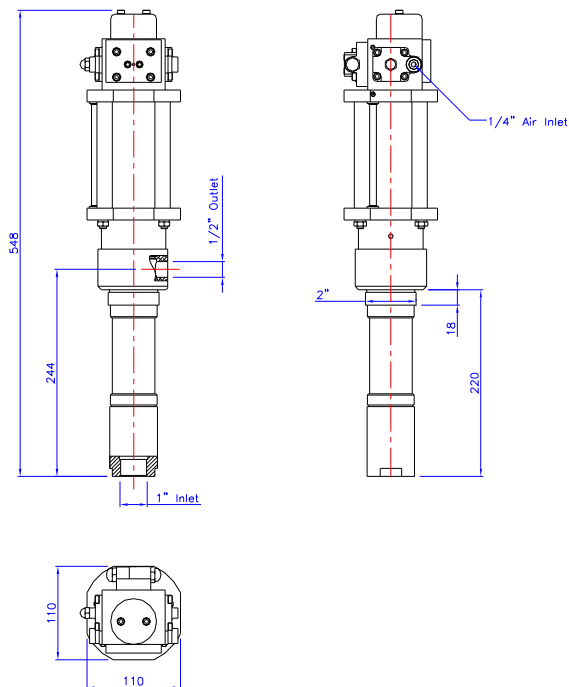

FOX OIL

STANDARD APPLICATION

Oils, lubricants, multiple distribution centralized systems

FEATURES

High Performances, extremely reliable



TECHNICAL DATA

Type	Double Effect
Adjustable Flow Rate	24,6 l/min
Pressure Ratio	8:1
Outlet Port	3/4" Gas Thread
Inlet Port	1" 1/4" Gas Thread
Maximum cycles per minute	90
Air consumption per cycle	2,28 dm ³
Air consumption at 55 cpm	206 NI/min
Air Inlet	1/4" Gas
Air Supply Pressure (Min / Max)	1 / 6.8 bar
Weight	14,5 Kg
Noise Level	<78 dB [A]

DIMENSIONS

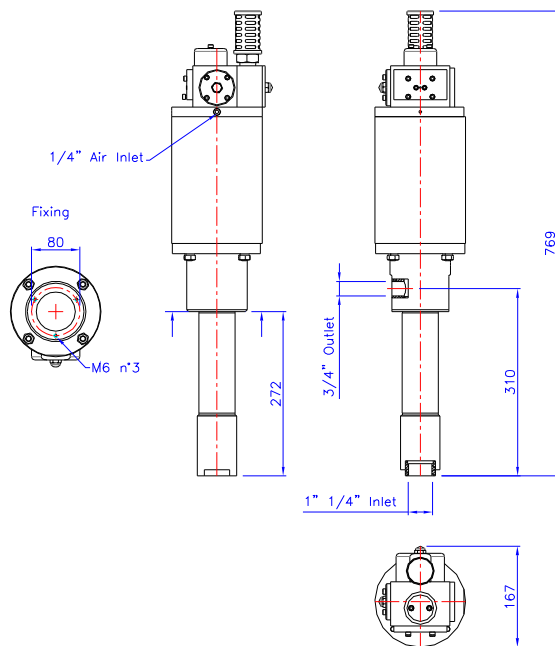

GENERAL APPLICATION PUMPS



FOX MURO

STANDARD APPLICATION

Viscous fluids

FEATURES

High Performances, extremely reliable, Stainless Steel frame, PTFE Gaskets



TECHNICAL DATA

Type	Double Effect
Adjustable Flow Rate	30 l/min
Pressure Ratio	5:1
Outlet Port	3/4" Gas Thread
Inlet Port	1" 1/4" Gas Thread
Maximum cycles per minute	75
Air consumption per cycle	1,19 dm ³
Air consumption at 55 cpm	89 NI/min
Air Inlet	1/4" Gas
Air Supply Pressure (Min / Max)	1 / 6.8 bar
Weight	16 Kg
Noise Level	<78 dB [A]

DIMENSIONS

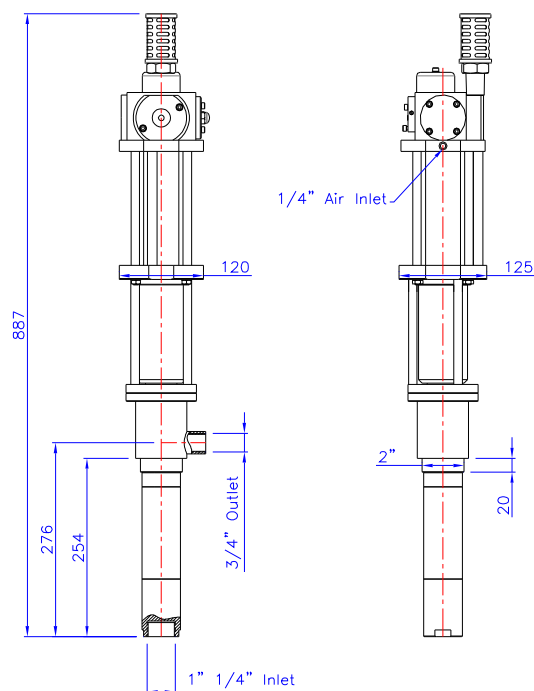



ACCESSORIES

AIR TREATMENT KIT

Pressure regulators, manometers, filters, for a correct supply of the pneumatic pump



BEAT COUNTER

Every pump can be provided with a beat counter

MONITORING DEVICE

Every pump can be provided with an electronic monitoring device, which can be used to operate the pump, diagnosis or statistics.

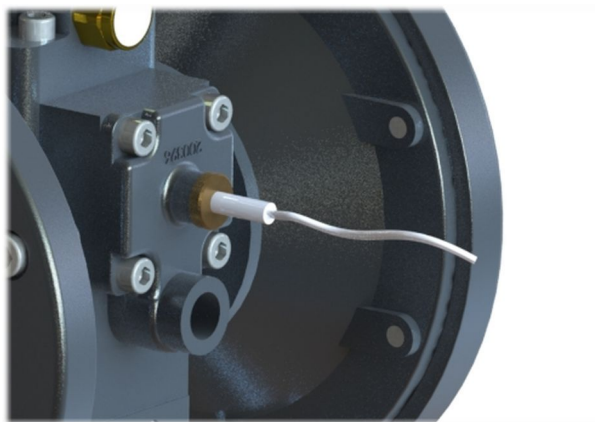

CUSTOMIZATION AND OTHER ACCESSORIES

PUMPS WITH ISO CONNECTIONS FOR PLC CONTROL

CUSTOMIZED SUCTION HEIGHT

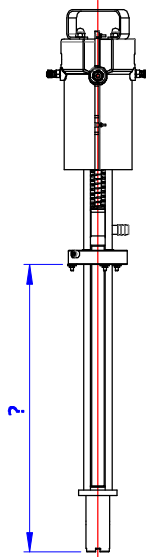

BRACKETS AND ADAPTERS



Wall bracket

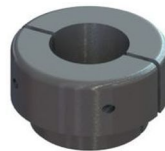

Adapter for barrels



Adapter for tanks

BARREL COVERS

ABS BARREL COVER

ABS Barrel Cover for Alko Pumps. Stainless Steel sieve.

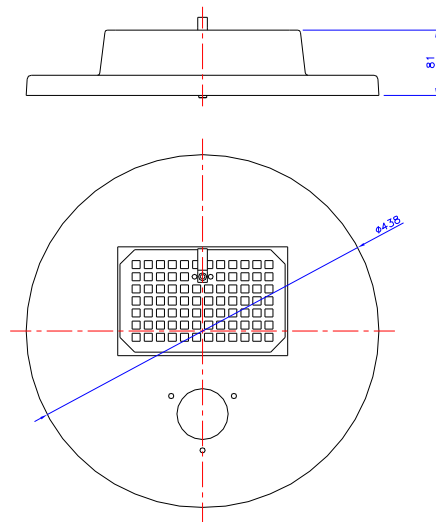

STAINLESS STEEL BARREL COVER

Stainless Steel Barrel Cover for Alko Pumps. Stainless Steel sieve.

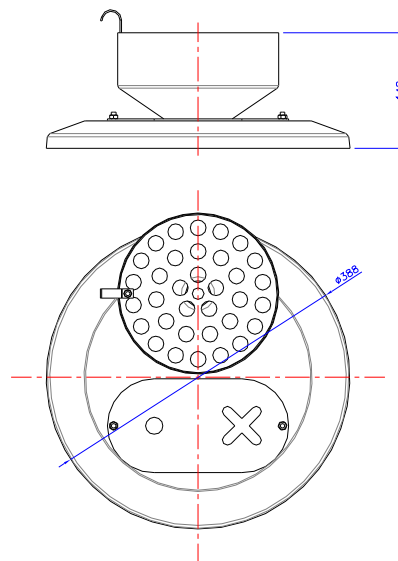

TANKS & BARRELS

STAINLESS STEEL TANK

Stainless Steel Tank with inspectionable lid. Cover with customizable holes. Available with or without wheels. Standard size: 40 / 65 / 100 liters. Others sizes upon request.

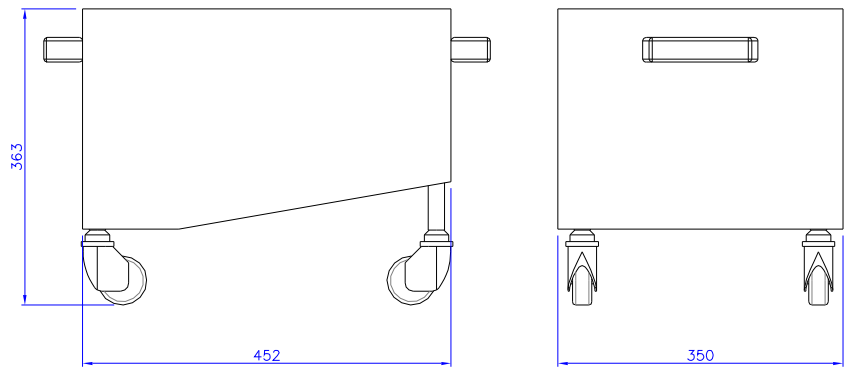

Dimensions for 40 liters size

TANK WITH INTERSTITIAL SPACE IN STAINLESS STEEL

Tank with Interstitial Space in Stainless Steel to easily control the temperature of the processed fluid. Inspectionable lid with customizable holes. Standard size: 55 liters. Others sizes upon request.

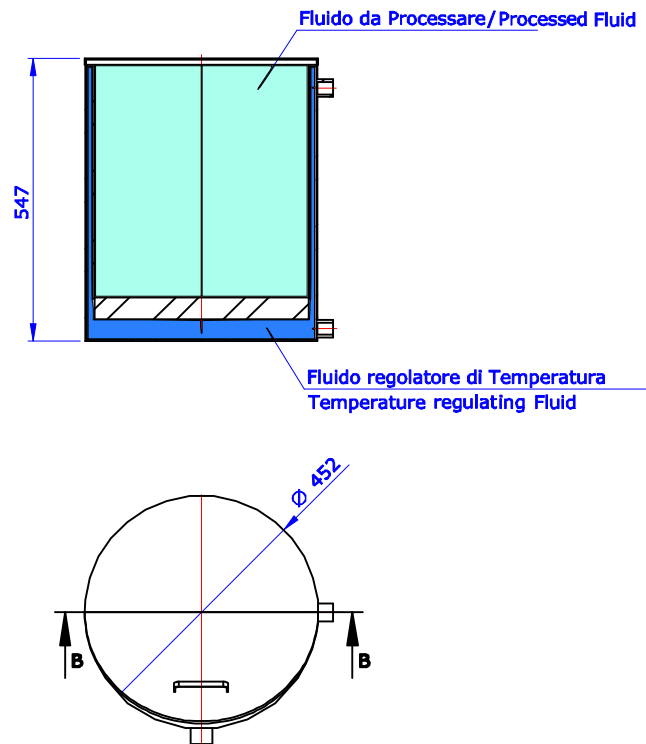

COMPLETE SETS

TANK / PISTON PUMP SET

Pre-assembled. Customizable with every accessory.



SET PUMP/BARREL COVER

Barrel Cover in Stainless Steel. Customizable suction height and with accessories.



INLINE FILTER

DESCRIPTION

Stainless Steel filter, inspectionable, interchangeable net

TECHNICAL DATA

Material	Stainless Steel
Gasket Material	PTFE
Mesh	240 μm 600 μm
Inlet Port	1/2" n°1
Outlet Port	1/2" n°2

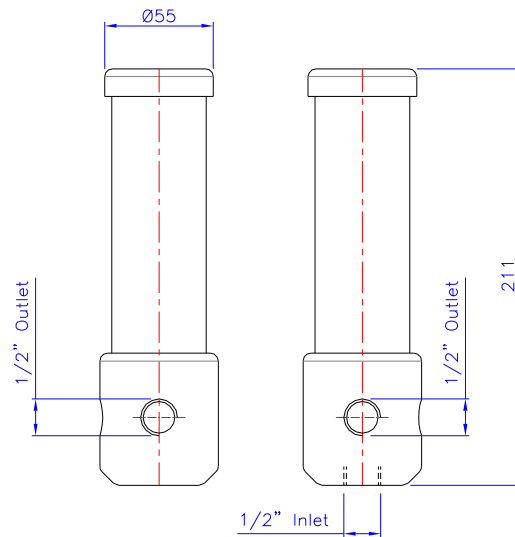

HEATING BANDS 30L

HEATING BANDS FOR 30 LITER BARRELS

Heating Bands are a specific application of thin silicone resistances.
Supplied with an adjustable thermostat and an easy and fast tightening.

TECHNICAL DATA

Isolation Material	Silicone
Class	I/II
Working Temperature (Environment)	-30°C ÷ +180°C
Connection	Electrical Wire
Settable Temperature	0°C ÷ +180°C
Tightening	Spring hooks
IP Protection	54
Testing regulations	EN 60355-1 EN 50106



	Ø300 ÷ Ø330 Barrel	Ø330 ÷ Ø360 Barrel
Length	880 mm	950 mm
Height	95 mm	115 mm
Voltage	230 V	230 V
Power	300 W	500 W

Also available in customized sizes and voltages

HEATING BANDS 200L

HEATING BANDS FOR 200 LITER BARRELS

Heating Bands are a specific application of thin silicone resistances.
Supplied with an adjustable thermostat and an easy and fast tightening.

TECHNICAL DATA

Isolation Material	Silicone
Class	I/II
Working Temperature (Environment)	-30°C ÷ +180°C
Connection	Electrical Wire
Settable Temperature	0°C ÷ +180°C
Tightening	Spring hooks
IP Protection	54
Testing regulations	EN 60355-1 EN 50106



	Ø600 Barrel
Length	1700 mm
Height	145 mm
Voltage	230 V
Power	1500 W

Also available in customized sizes and voltages

EXTERNAL HEATER

EXTERNAL HEATER

Heater to be installed in line after the pump. Heats the processed fluid

Voltage and Frequency
Inlet and Outlet Port
Thermo Controller

220V 50Hz
3/8" Gas Thread (Hose nozzle Ø19 mm)
Upon Request

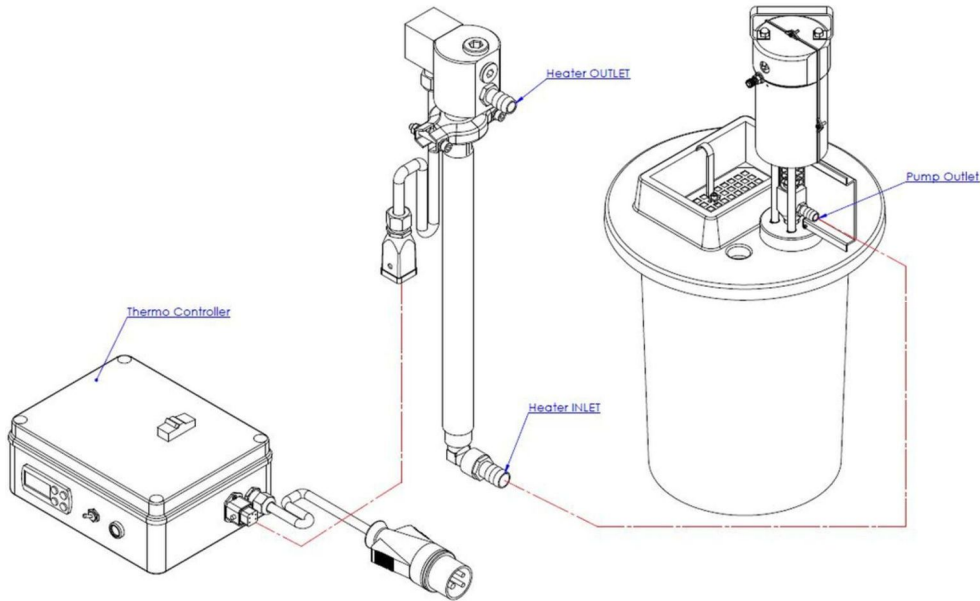

DIMENSIONS

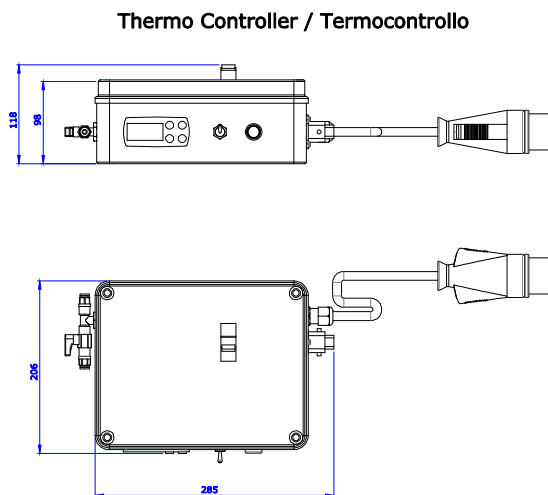
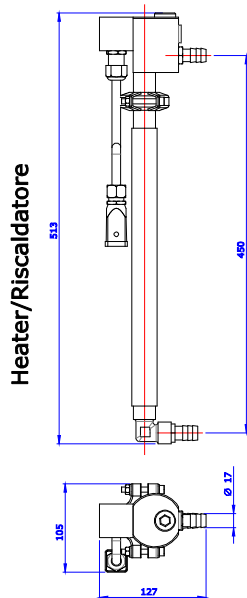

LIFTERS

DESCRIPTION

Winch lifter, Stainless Steel frame. It facilitates pump handling, for example in barrel exchanges.

Weight: 50 Kg

Maximum lifting capacity: 180 Kg

